

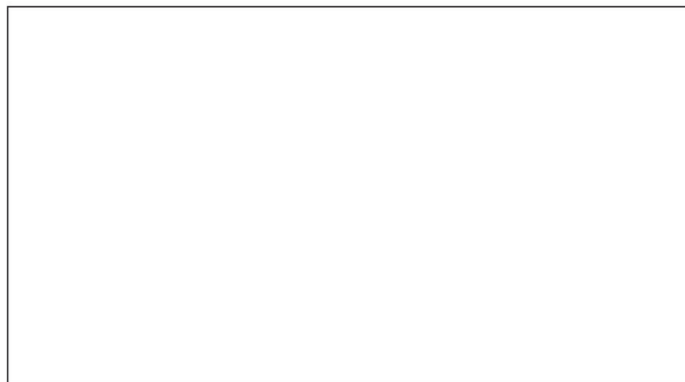

Distributed By



**浙江信瑞重工科技有限公司**  
ZHEJIANG TRUEMAX ENGINEERING CO.,LTD.

公司地址 (Office Addr): 杭州市滨江区滨盛路1505号银丰大厦11楼  
11th Floor Yinfeng Building, No.1505 Bingsheng Road, Hangzhou, China  
工厂地址 (Factory Addr): 海宁市尖山新区海丰路118号  
No.118 Haifeng Road, Jianshan Industrial Development Zone, Haining, China  
电话 (Tel): 0086-571-85803511 传真 (Fax): 0086-571-85803522 邮箱 (Email): sales@truemax.cn  
网址 (Website): www.truemax.cn www.truemaxeng.com m.truemax.cn



CT/CPB/20.05/1000/CH&ENG/1



**B8 SERIES**

# 混凝土布料机 CONCRETE PLACING BOOM



**TRUEMAX GROUP LIMITED 骏瑞集团**

浙江信瑞重工科技有限公司  
ZHEJIANG TRUEMAX ENGINEERING CO.,LTD.

杭州骏瑞机电设备有限公司  
HANGZHOU TRUEMAX MACHINERY & EQUIPMENT CO.,LTD.





# 目录 CATALOGUE

**1** 管柱内爬式液压布料机  
Column Climbing Placing Boom

**2** 模架式液压布料机  
Formwork Climbing Placing Boom

**3** 移动式液压布料机  
Spider Placing Boom

**4** 车载式液压布料机  
Mobile Spider Placing Boom

**5** 塔式液压布料机  
Lattice Tower Placing Boom

**6** 船载式液压布料机  
Mobile Boat Placing Boom

**7** 项目案例  
Project Case

**管柱内爬式液压布料机**  
**COLUMN CLIMBING PLACING BOOM**

技术参数 Main Technical Specifications

项目 ITEMS		单位 UNITS	PB28A-3R-II [HG28A-3R-II] *	PB32A-3R-II [HG32A-3R-II] *	PB33A-4R-II [HG33A-4R-II] *	
性能 Performance	最大布料半径 Max Radius of Placing Boom	m	27.7	31.7	32.4	
	独立高度(至臂根铰点) Free standing Height(To The Joint Between The End of The Boom And Slewing Platform)	m	21.3	21.3	21.3	
	回转范围 Slewing Range	/	360°	360°	360°	
	环境温度 Circumstance Temperature	°C	-20~55	-20~55	-20~55	
	电源(根据客户需求) Power(subject to Customer)	/	380V/50Hz	380V/50Hz	380V/50Hz	
臂架 Boom	输送管径 Delivery Pipeline Diameter	mm×mm	Φ 133×4.5	Φ 133×4.5	Φ 133×4.5	
	输送软管直径 Delivery Hose Diameter	"×mm	5"×3000	5"×3000	5"×3000	
	第一节臂 1st Section	长度 Length	m	10.5	14.5	9.51
		角度 Articulation	/	0°~86°	0°~86°	0°~86°
	第二节臂 2nd Section	长度 Length	m	9.2	9.2	7.56
		角度 Articulation	/	0°~180°	0°~180°	0°~180°
	第三节臂 3rd Section	长度 Length	m	8	8	7.65
		角度 Articulation	/	0°~180°	0°~180°	0°~180°
	第四节臂 4th Section	长度 Length	m	/	/	7.72
		角度 Articulation	/	/	/	0°~180°
液压油牌号 Type of Hydraulic Oil	环境温度 Circumstance Temperature 5°C-55°C	°C	HM46抗磨液压油 Hm46 Anti-wear hydraulic oil	HM46抗磨液压油 Hm46 Anti-wear hydraulic oil	HM46抗磨液压油 Hm46 Anti-wear hydraulic oil	
	环境温度 Circumstance Temperature -20°C-5°C	°C	HM32抗磨液压油 Hm32 Anti-wear hydraulic oil	HM32抗磨液压油 Hm32 Anti-wear hydraulic oil	HM32抗磨液压油 Hm32 Anti-wear hydraulic oil	
电机 Motor	功率 Power	kW	11	11	18.5	
系统压力 Hydraulic Pressure		MPa	28	28	30	
回转方式 Mode of Slewing		/	齿轮回转 Gear Slewing	齿轮回转 Gear Slewing	齿轮回转 Gear Slewing	
应用场景 Application scenario		/	楼面内爬或电梯井内爬 Floor Climbing or Shaft Climbing			
平衡臂 Balance Arm		/	/	/	/	
总重量 Total Weight		kg	16200	18150	20100	
最大吊装单元 Max Lifting Unit		kg	4100	4150	4800	

\*可根据客户要求定制电压频率  
The voltage frequency can be customized according to customer's requirement

配置参数如有更改,恕不另行通知  
Configuration parameters are subject to change without notice

# 构造及工作范围 STRUCTURE AND SCOPE OF WORK

PB28A-3R-II [HG28A-3R-II]

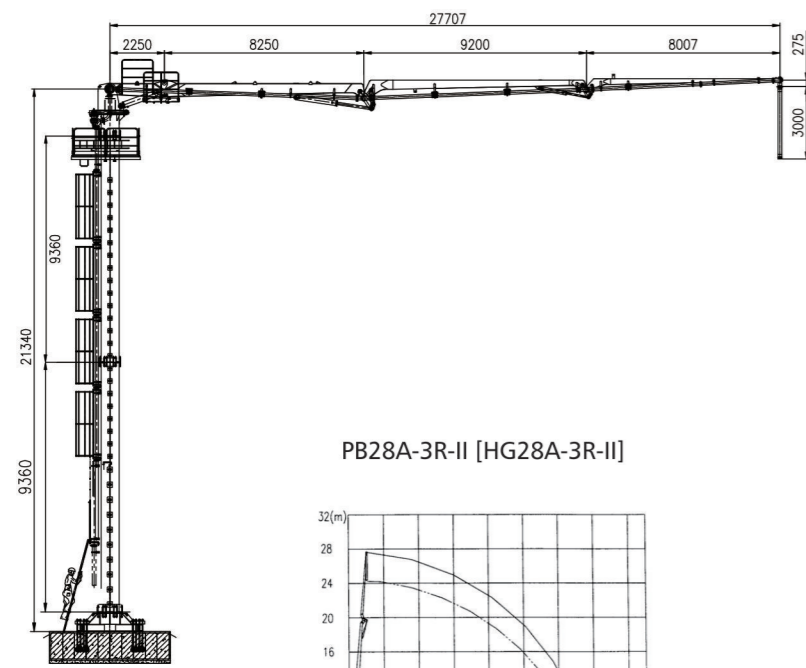

PB28A-3R-II [HG28A-3R-II]

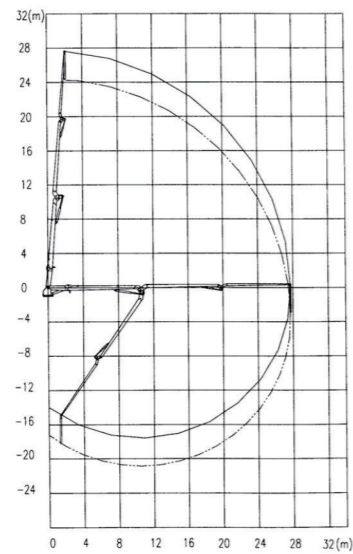

PB32A-3R-II [HG32A-3R-II]

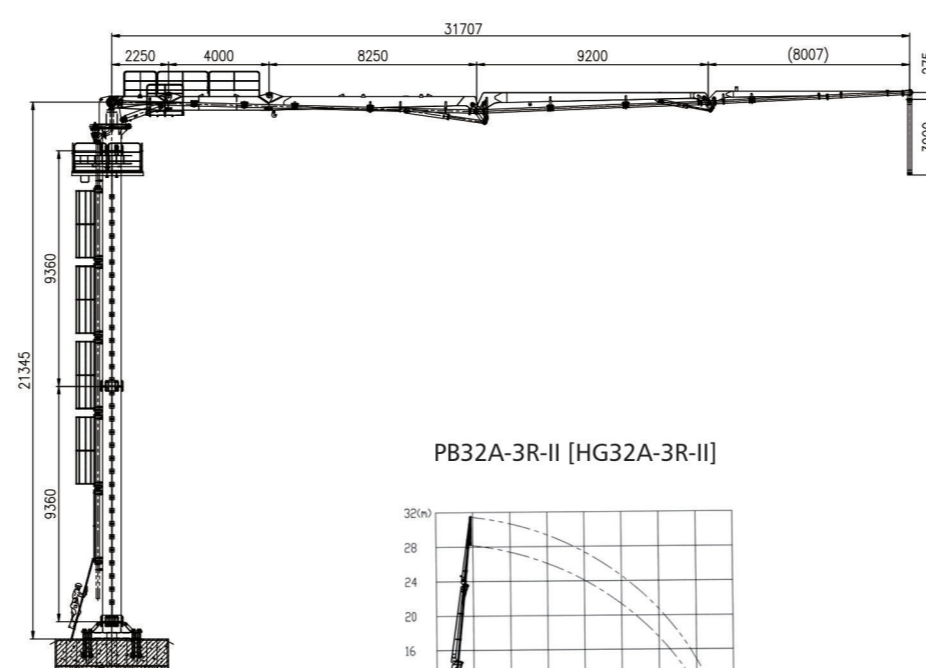

PB32A-3R-II [HG32A-3R-II]

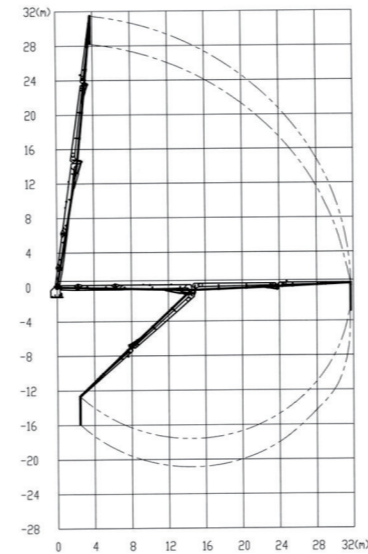

PB33A-4R-II [HG33A-4R-II]

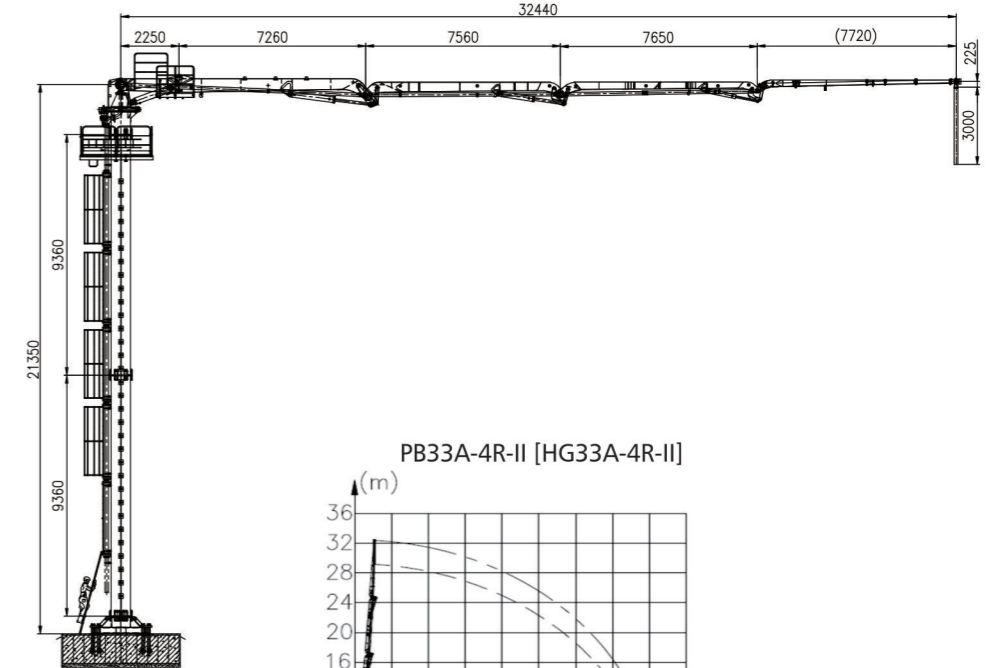

PB33A-4R-II [HG33A-4R-II]

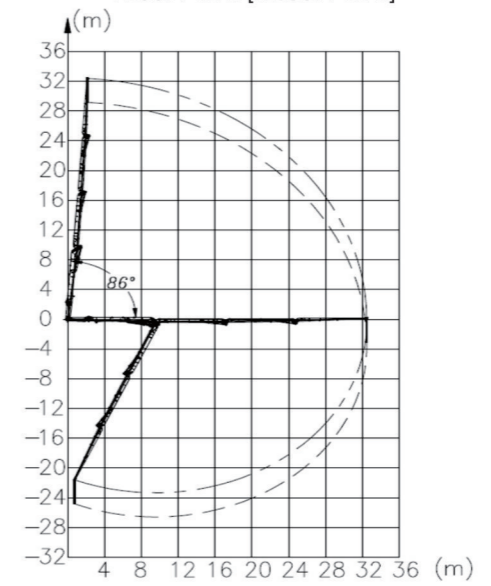



## 主要特点 MAIN FEATURES

- 整机重量轻,有利于楼面承载。  
The light weight of the whole machine is conducive to floor loading.
- 液压泵站和电控柜集成在下支座上,方便现场安装,减少故障率。  
The hydraulic pump station and electric control cabinet are integrated on the lower support, which is convenient for on-site installation and reduces the failure rate.
- 吊装单元重量大大减轻,降低了工地吊装要求  
The weight of the lifting unit is greatly reduced, with less site lifting capacity requirement.
- 不带平衡臂,回转施工更灵活。  
Without balance arm, more flexible on the operation.

## 可选配置 OPTIONAL

- 立柱: 可根据不同工况定制不同规格立柱4M、5M、6M、10M。  
Columns: can be customized columns of different length according to working application 4M, 5M, 6M, 10M.
- 爬升方式: 楼面内爬,电梯井内爬。  
Mode of climbing: floor climbing, shaft climbing.



HBC或AUTECH遥控器  
HBC or AUTECH Remote Control



电比例阀  
Electric Proportional Control



无线遥控器  
Radio Remote Control



有线遥控器  
Cable Remote Control



开关量控制阀组  
Switch Control



欧姆龙/施耐德电气元件  
Omron/Schneider  
Electrical Component

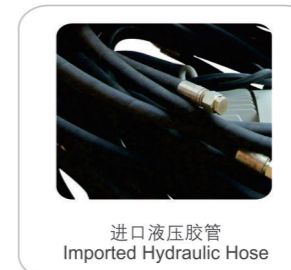

进口液压胶管  
Imported Hydraulic Hose



快插接头  
Push-in Connector



楼面内爬框架  
Floor Frame



电梯井内爬框架  
Shaft Frame



齿轮回转  
Gear Slewing



回转缓冲阀  
Slewing Cushion Valve

## 模架式液压布料机 FORMWORK CLIMBING PLACING BOOM

### 技术参数 Main Technical Specifications

项目 ITEMS		单位 UNITS	PB21AM-3R [HG21AM-3R]	
性能 Performance	最大布料半径 Max Radius of Placing Boom	m	21	
	独立高度 (至臂根铰点) Free standing Height	m	4.2	
	回转范围 Slewing Range	/	360°	
	环境温度 Circumstance Temperature	°C	-20~55	
	电源(根据客户需求) Power(subject to Customer)	/	380V/50Hz	
臂架 Boom	输送管径 Delivery Pipeline Diameter	mm×mm	Φ 133×4.5	
	输送软管直径 Delivery Hose Diameter	"×mm	5"×3000	
	第一节臂 1st Section	长度 Length	m	8.4
		角度 Articulation	/	0°~90°
	第二节臂 2nd Section	长度 Length	m	6.9
		角度 Articulation	/	0°~180°
第三节臂 3rd Section	长度 Length	m	5.7	
	角度 Articulation	/	0°~220°	
液压油牌号 Type of Hydraulic Oil	环境温度 Circumstance Temperature 5°C-55°C	°C	HM46抗磨液压油 Hm46 Anti-wear hydraulic oil	
	环境温度 Circumstance Temperature -20°C-5°C	°C	HM32抗磨液压油 Hm32 Anti-wear hydraulic oil	
电机 Motor	功率 Power	kW	7.5	
系统压力 Hydraulic Pressure		MPa	28	
回转方式 Mode of Slewing		/	齿轮回转 Gear Slewing	
应用场景 Application scenario		/	模架爬升 Formwork Climbing	
总重量 Total Weight		kg	6400	
最大吊装单元 Max Lifting Unit		kg	5200	

\*可根据客户要求定制电压频率  
The voltage frequency can be customized according to customer's requirement

配置参数如有更改,恕不另行通知  
Configuration parameters are subject to change without notice

## 构造及工作范围 STRUCTURE AND SCOPE OF WORK

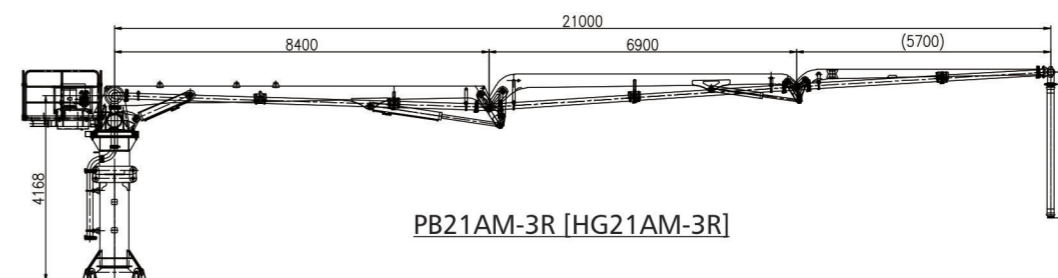

PB21AM-3R [HG21AM-3R]

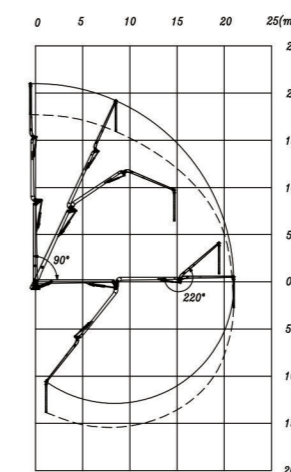

PB21AM-3R [HG21AM-3R]

## 主要特点 MAIN FEATURES

- R型三臂结构, 液压驱动, 折叠展开灵活, 布料范围广。  
Three arms design "R" folding, The machine is fully driven by hydraulic and can slew flexibly, with wide working range.
- 模块化设计理念和快速安装理念, 通过销轴快速连接各个模块, 实现设备快速拆装。  
The machine adopts modular design which can be linked quickly by pin shafts, easy to install disassemble and transport.
- 配备无线遥控和有线遥控两种操作模式, 操作轻松方便。  
Two modes of operation: radio remote control and cable remote control, easy to operate.
- 设备随爬升模架一起快速爬升, 高效施工。  
The machine climbs by climbing frame to reduce the workload of climbing, and increase the efficiency.
- 液压电气元件采用国内外知名品牌, 设备质量稳定可靠。  
The main electronic components are products of the world-famous brand, with high-quality.

## 移动式液压布料机 SPIDER PLACING BOOM

### 技术参数 Main Technical Specifications

项目 ITEMS		单位 UNITS	PB17B-3R-II* [HG17B-3R-II]	PB21B-3R [HG21B-3R]	
性能 Performance	最大布料半径 Max Radius of Placing Boom	m	17	21	
	独立高度 (至臂根铰点) Free standing Height	m	2.7	3	
	回转范围 Slewing Range	/	360°	360°	
	环境温度 Circumstance Temperature	°C	-20~55	-20~55	
	电源 (根据客户需求) Power(subject to Customer)	/	380V/50Hz	380V/50Hz	
臂架 Boom	输送管径 Delivery Pipeline Diameter	mm×mm	Φ133×4.5	Φ133×4.5	
	输送软管直径 Delivery Hose Diameter	"×mm	5"×3000	5"×3000	
	第一节臂 1st Section	长度 Length	m	7.1	8.4
		角度 Articulation	/	0°~86°	0°~90°
	第二节臂 2nd Section	长度 Length	m	5.5	6.9
		角度 Articulation	/	0°~180°	0°~180°
第三节臂 3rd Section	长度 Length	m	4.5	5.7	
	角度 Articulation	/	0°~180°	0°~180°	
液压油牌号 Type of Hydraulic Oil	环境温度 Circumstance Temperature 5°C-55°C	°C	HM46抗磨液压油 Hm46 Anti-wear hydraulic oil		
	环境温度 Circumstance Temperature -20°C-5°C	°C	HM32抗磨液压油 Hm32 Anti-wear hydraulic oil		
电机 Motor	功率 Power	kW	5.5	7.5	
系统压力 Hydraulic Pressure		MPa	25	28	
回转方式 Mode of Slewing		/	蜗轮蜗杆传动 Turbo Worm Drive	齿轮回转 Gear Slewing	
应用场景 Application scenario		/	移动式 Mobile		
总重量 Total Weight		kg	6500	9150	
最大吊装单元 Max Lifting Unit		kg	1520	5850	

\*可根据客户要求定制电压频率  
The voltage frequency can be customized according to customer's requirement

配置参数如有更改,恕不另行通知  
Configuration parameters are subject to change without notice

## 构造及工作范围 STRUCTURE AND SCOPE OF WORK

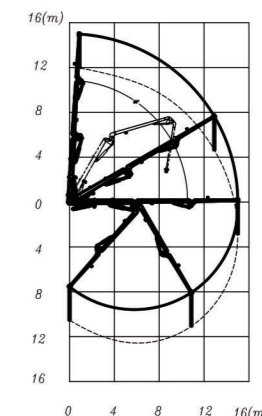
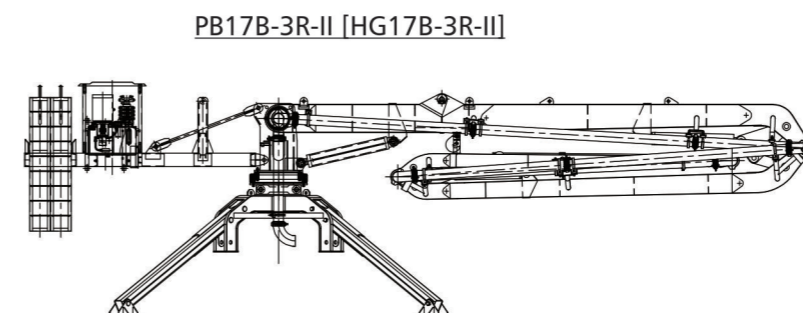

PB17B-3R-II  
[HG17B-3R-II]

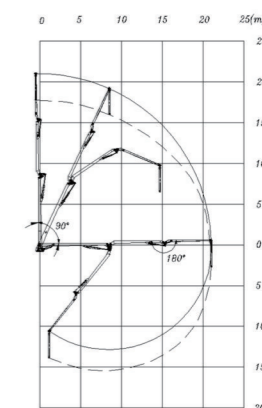
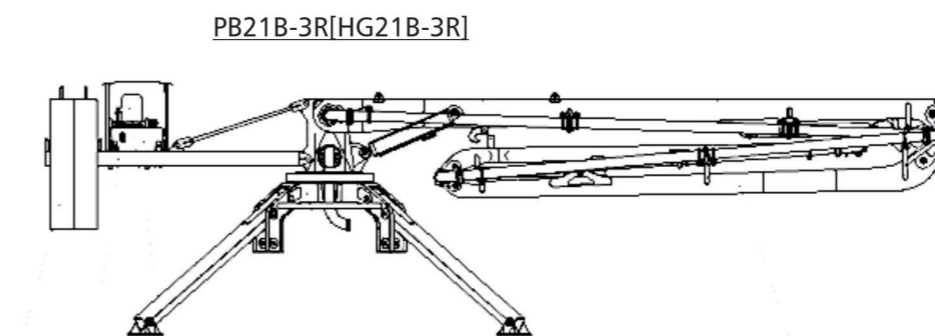

PB21B-3R  
[HG21B-3R]

## 主要特点 MAIN FEATURES

- 三节臂设计,全液压驱动,折叠展开灵活方便,可360°回转,布料范围广。  
Three arms design "R" folding, The machine is fully driven by hydraulic, and can slew flexibly with wide working range.
- 配备无线遥控和有线遥控两种操作方式,操作轻松方便。  
Two modes of operation: radio remote control and cable remote control, easy to operate.
- 整机重量轻,可根据施工的需要,在施工范围内通过塔机灵活吊装移动。  
The total weight is light, customer can lifting it easily on the job site.
- 底架为斜支腿结构,工作状态平稳固定。  
The bottom frame is inclined outrigger structure, the working state is table and fixed.

## 车载式液压布料机 MOBILE SPIDER PLACING BOOM

### 技术参数 Main Technical Specifications

项目 ITEMS		单位 UNITS	PB17D-3R [HG17D-3R]	
性能 Performance	最大布料半径 Max Radius of Placing Boom	m	17	
	整机高度 Overall Height	m	2.9	
	回转范围 Slewing Range	/	360°	
	环境温度 Circumstance Temperature	°C	-20~55	
	电源(根据客户需求) Power(subject to Customer)	/	380V/50Hz	
臂架 Boom	输送管径 Delivery Pipeline Diameter	mm×mm	Φ133×4.5	
	输送软管直径 Delivery Hose Diameter	"×mm	5"×3000	
	第一节臂 1st Section	长度 Length	m	7.1
		角度 Articulation	/	0°~86°
	第二节臂 2nd Section	长度 Length	m	5.5
		角度 Articulation	/	0°~180°
第三节臂 3rd Section	长度 Length	m	4.5	
	角度 Articulation	/	0°~180°	
液压油牌号 Type of Hydraulic Oil	环境温度 Circumstance Temperature 5°C-55°C	°C	HM46抗磨液压油 Hm46 Anti-wear hydraulic oil	
	环境温度 Circumstance Temperature -20°C-5°C	°C	HM32抗磨液压油 Hm32 Anti-wear hydraulic oil	
电机 Motor	功率 Power	kW	5.5	
系统压力 Hydraulic Pressure		MPa	25	
回转方式 Mode of Slewing		/	蜗轮蜗杆传动 Turbo Worm Drive	
应用场景 Application scenario		/	车载式 Wheel Type	
总重量 Total Weight		kg	7950	
最大吊装单元 Max Lifting Unit		kg	5850	

\*可根据客户要求定制电压频率  
The voltage frequency can be customized according to customer's requirement

配置参数如有更改,恕不另行通知  
Configuration parameters are subject to change without notice

## 构造及工作范围 STRUCTURE AND SCOPE OF WORK

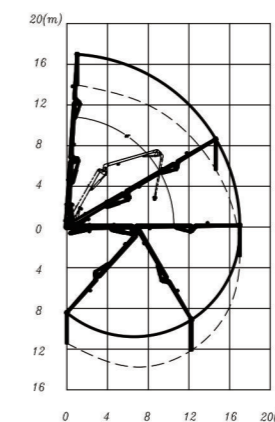
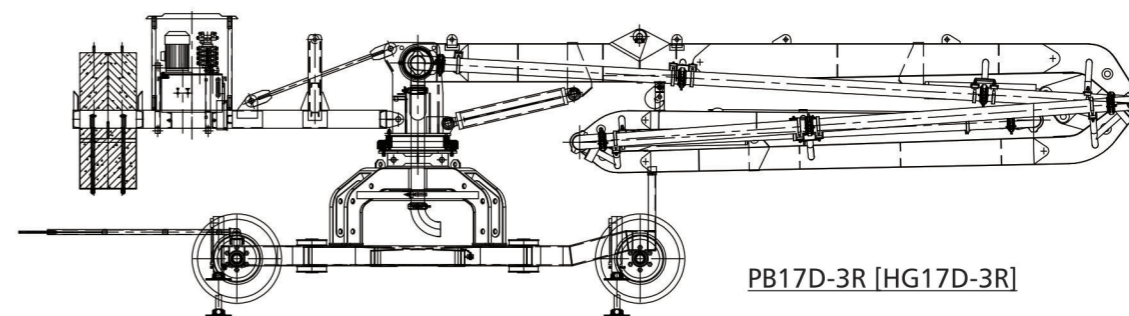

PB17D-3R  
[HG17D-3R]

## 主要特点 MAIN FEATURES

- R型三臂结构,液压驱动,折叠展开灵活,布料范围广。  
Three arms design "R" folding .The machine is fully driven by hydraulic and can slew flexibly, with wide working range.
- 配备无线遥控和有线遥控两种操作模式,操作轻松方便。  
Two modes of operation: radio remote control and cable remote control, easy to operate.
- 带车架体可轻松拖走,可根据布料的需要,在施工范围内轻易移动。  
The frame body can be easily dragged away, and can be easily moved within the construction scope according to the need of material placing.
- 液压电气元件采用国内外知名品牌,设备质量稳定可靠。  
The main electronic components are products of the world-famous brand, with high-quality.



## 塔式液压布料机 LATTICE TOWER PLACING BOOM

### 技术参数 Main Technical Specifications

项目 ITEMS		单位 UNITS	PB38BT-4R-E [HG38BT-4R-E]	PB51AT-4R-E [HG51AT-4R-E]	
性能 Performance	最大布料半径 Max Radius of Placing Boom	m	38	51	
	独立高度 (至臂根铰点) Free standing Height	m	40	46	
	回转范围 Slewing Range	/	360°	360°	
	环境温度 Circumstance Temperature	°C	-20~55	-20~55	
	电源 (根据客户需求) Power(subject to Customer)	/	380V/50Hz	380V/50Hz	
臂架 Boom	输送管径 Delivery Pipeline Diameter	mm×mm	Φ133×4.5	Φ133×4.5	
	输送软管直径 Delivery Hose Diameter	"×mm	5"×3000	5"×3000	
	第一节臂 1st Section	长度 Length	m	14.91	21.5
		角度 Articulation	/	0°~86°	0°~86°
	第二节臂 2nd Section	长度 Length	m	7.56	9.8
		角度 Articulation	/	0°~180°	0°~180°
	第三节臂 3rd Section	长度 Length	m	7.65	9.8
		角度 Articulation	/	0°~180°	0°~180°
	第四节臂 4th Section	长度 Length	m	7.72	9.9
角度 Articulation		/	0°~180°	0°~180°	
液压油牌号 Type of Hydraulic Oil	环境温度 Circumstance Temperature 5°C-55°C	°C	HM46抗磨液压油 Hm46 Anti-wear hydraulic oil		
	环境温度 Circumstance Temperature -20°C-5°C	°C	HM32抗磨液压油 Hm32 Anti-wear hydraulic oil		
电机 Motor	功率 Power	kW	37.5	37.5	
系统压力 Hydraulic Pressure		MPa	30	30	
回转方式 Mode of Slewing		/	齿轮回转 Gear Slewing		
顶升套架 Telescopic Cage		/	含:泵站、油缸 Included pump, cylinder		
标准节 Mast Section L68A1		m	(1.6×1.6×3)×10	(2×2×3)×12	
基础节 Base Section		m	(1.6×1.6×7.5)×1	(2×2×7.5)×1	
应用场景 Application scenario		/	塔式 Lattice Type		
总重量 Total Weight		kg	43000	66000	
最大吊装单元 Max Lifting Unit		kg	9700	14800	

\*可根据客户要求定制电压频率  
The voltage frequency can be customized according to customer's requirement

配置参数如有更改,恕不另行通知  
Configuration parameters are subject to change without notice

## 构造及工作范围 STRUCTURE AND SCOPE OF WORK

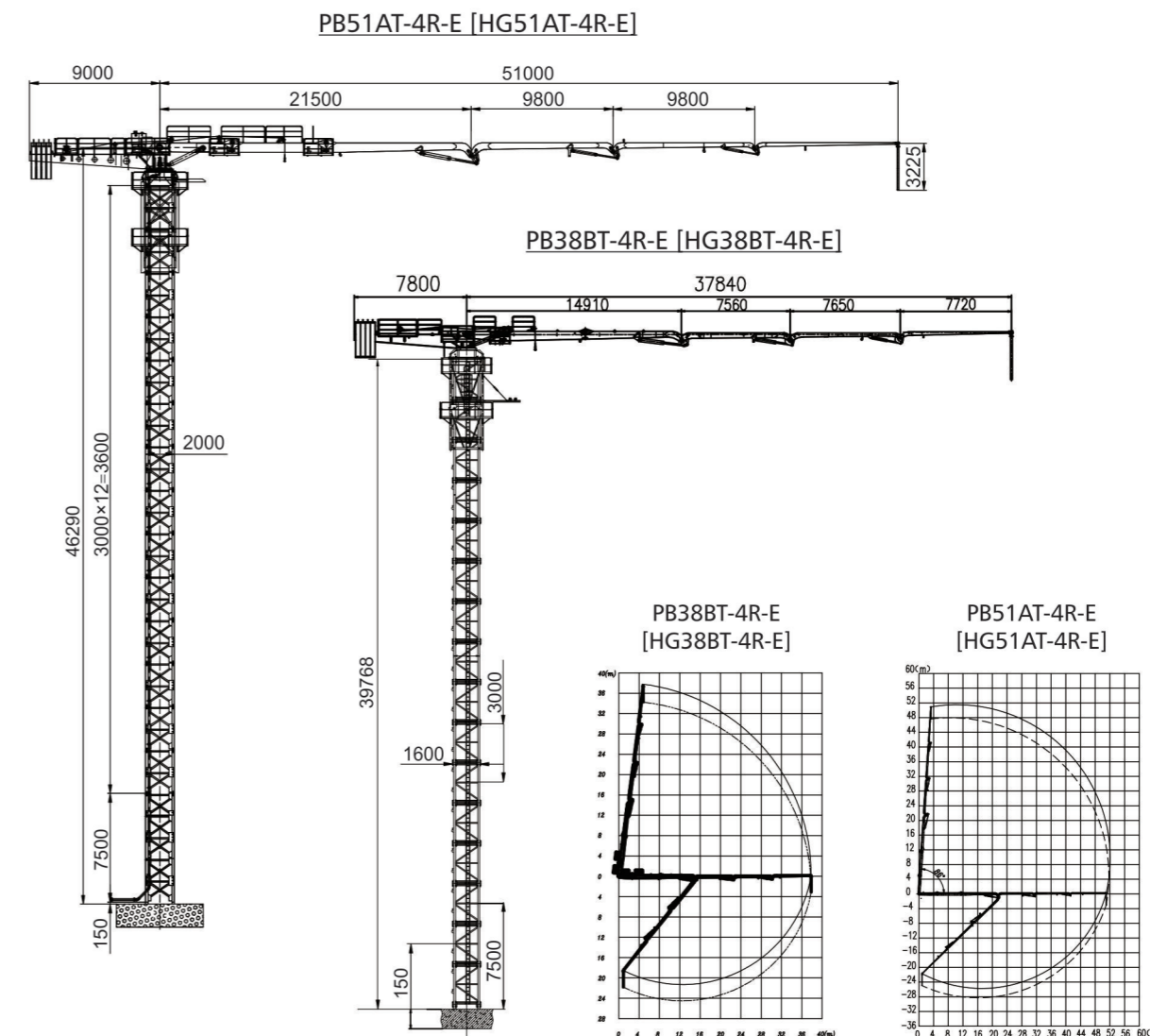

## 主要特点 MAIN FEATURES

- 将塔机的塔身与布料机的上装结合,既具有塔机自身加节的功能,又具有布料机布料的功能。  
Combining the tower body and boom assembly, which fully exhibits their respective: tower body can be added mast section to lengthen the height and boom can place the concrete.
- 配有起升机构,在爬升加节时,能自身起吊标准节。  
Equipped with lifting mechanism, it can lift mast section by itself standing height.
- 配备无线遥控操作方式,操作轻松方便。  
Radio remote control, easy to operate.
- 液压电气元件采用国内外知名品牌,设备质量稳定可靠。  
The main electronic components are products of the world-famous brand, with high-quality.
- 电比例控制技术,臂架动作冲击更小,工作更平稳。  
Electro-hydraulic proportional control technology, work smoothly with more stable.

## 船载式液压布料机 MOBILE BOAT PLACING BOOM

### 技术参数 Main Technical Specifications

项目 ITEMS		单位 UNITS	PB21AM-3R [HG21AM-3R]	
性能 Performance	最大布料半径 Max Radius of Placing Boom	m	21	
	独立高度 (至臂根铰点) Free standing Height	m	4.2	
	回转范围 Slewing Range	/	360°	
	环境温度 Circumstance Temperature	°C	-20~55	
	电源(根据客户需求) Power(subject to Customer)	/	380V/50Hz	
臂架 Boom	输送管径 Delivery Pipeline Diameter	mm×mm	Φ133×4.5	
	输送软管直径 Delivery Hose Diameter	"×mm	5"×3000	
	第一节臂 1st Section	长度 Length	m	8.4
		角度 Articulation	/	0°~90°
	第二节臂 2nd Section	长度 Length	m	6.9
		角度 Articulation	/	0°~180°
第三节臂 3rd Section	长度 Length	m	5.7	
	角度 Articulation	/	0°~220°	
液压油牌号 Type of Hydraulic Oil	环境温度 Circumstance Temperature 5°C-55°C	°C	HM46抗磨液压油 Hm46 Anti-wear hydraulic oil	
	环境温度 Circumstance Temperature -20°C-5°C	°C	HM32抗磨液压油 Hm32 Anti-wear hydraulic oil	
电机 Motor	功率 Power	kW	7.5	
系统压力 Hydraulic Pressure		MPa	28	
回转方式 Mode of Slewing		/	齿轮回转 Gear Slewing	
应用场景 Application scenario		/	船载式 Mobile Boat	
总重量 Total Weight		kg	6400	
最大吊装单元 Max Lifting Unit		kg	5200	

\*可根据客户要求定制电压频率  
The voltage frequency can be customized according to customer's requirement

配置参数如有更改, 恕不另行通知  
Configuration parameters are subject to change without notice

## 构造及工作范围 STRUCTURE AND SCOPE OF WORK

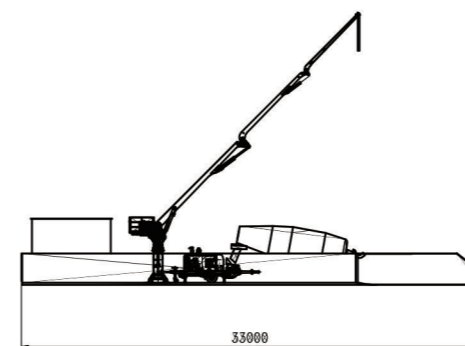

PB21AM-3R [HG21AM-3R]

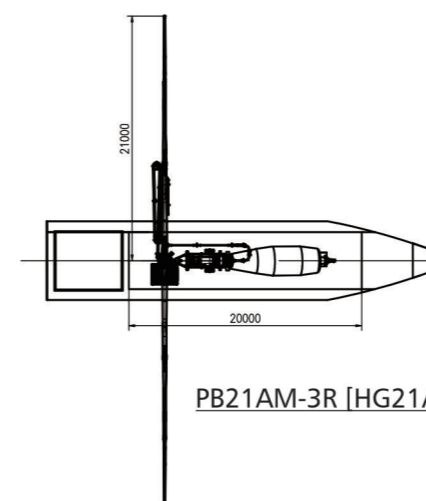
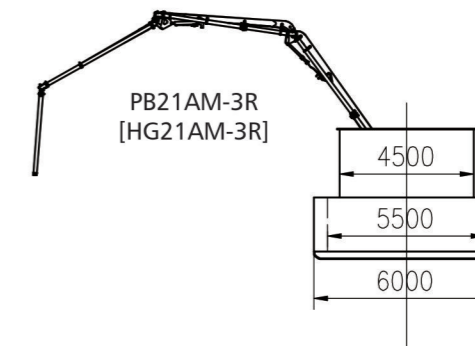

PB21AM-3R [HG21AM-3R]

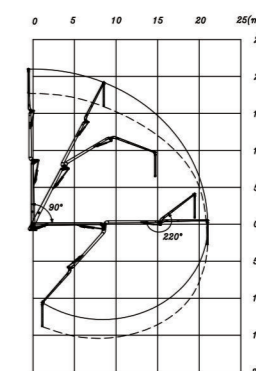

PB21AM-3R [HG21AM-3R]

## 主要特点 MAIN FEATURES

- 适用于某些对大型布料机和臂架泵车有限制的工作现场,如河上建筑物、河附近无道路等。船载式布料机可以很容易地通过河流到达现场。  
Applicable for some certain job-site that has restrictions on large placing boom and truck mounted boom pump, such as architecture over river, near the river without road and so on. Mobile Boat placing boom can be easy to the job-site through river.
- 模块化设计理念和快速安装理念,通过销轴快速连接各个模块,实现设备快速拆装。  
The machine adopts modular design which can be linked quickly by pin shafts, easy to install disassemble and transport.
- 适用于河上预制混凝土构件的生产,预制桥梁,桥柱,高速公路护栏,混凝土柱,桥墩等的生产。  
Applicable for the production of precast concrete structures over the river, the production of precast bridge beams, bridge columns, freeway barriers, concrete column, bridge pier, etc.
- 液压电气元件采用国内外知名品牌,设备质量稳定可靠。  
The main electronic components are products of the world-famous brand, with high-quality.
- 配备无线遥控和有线遥控两种操作模式,操作轻松方便。  
Two modes of operation: radio remote control and cable remote control, easy to operate.

# 国内项目案例 DOMESTIC PROJECT CASES



上海星港大厦 HG13A-3R  
Shanghai Xinggang Building



海南海航首府 HG17A-3Z  
Hainan Haihang Building



下凯富峡水电站 HG38BT-4R  
Xiakai Fuxia Hydropower Station



华佳彩光电 HG17D-3R  
Huajia Color Optoelectronics



温州瓯江北口大桥 HG28A-3R  
Wenzhou Oujian North Exit Bridge

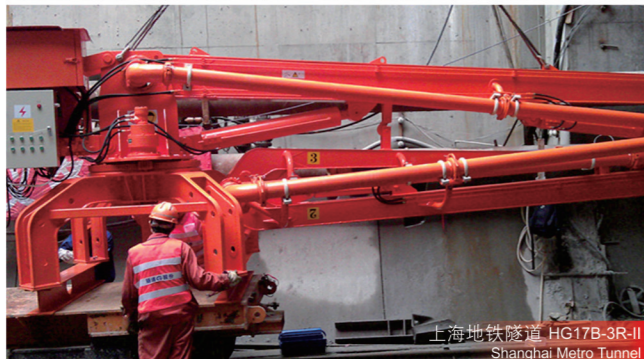

上海地铁隧道 HG17B-3R-II  
Shanghai Metro Tunnel



沈阳裕景中心 HG17B-3R  
Shenyang Yujing Center



杭海城际铁路 HG19AG  
Hanghai Intercity Railway



海河河道治理 HG21AM  
Shanghai River Regulation



海口中心大厦 HG32A-3R  
Haikou Center Building



上海董家渡金融城 HG17A-3Z  
Shanghai Dongjiadu Financial City



芜湖长江大桥 HG21AM  
Wuhu Yangtze River Bridge



舟山港主通道 HG19AG  
Main channel of Zhoushan Port



深圳新豪方天际花园 HG24A-3R  
Shenzhen Xinhao Fang Sky Garden



平潭海峡公铁大桥 HG21AM  
Pingtan Strait Highway and Railway Bridge

国外项目案例  
FOREIGN PROJECT CASES



马来西亚 MALAYSIA  
PB51AT-4R-E



印度尼西亚 INDONESIA  
PB21B-3R



印度尼西亚 INDONESIA  
PB17B-3R-II



阿联酋 UAE  
PB33A-4R



阿联酋 UAE  
PB28A-3R-II



马来西亚 MALAYSIA  
PB32A-3R-II



阿联酋 UAE  
PB32A-3R-II



澳大利亚 AUSTRALIA  
PB38BT-4R-E



阿联酋 UAE  
PB32A-3R-II



智利 CHILE  
PB17D-3R